

SMT-Based Learning of Weighted Automata

Submitted to CAV

Kevin Batz, Tiago Ferreira, Alexandra Silva

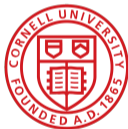

Cornell University.

PWND2 PI Meeting, Portland, OR

February 10, 2026

Recap: Network Modeling and Verification with Weighted NetKAT

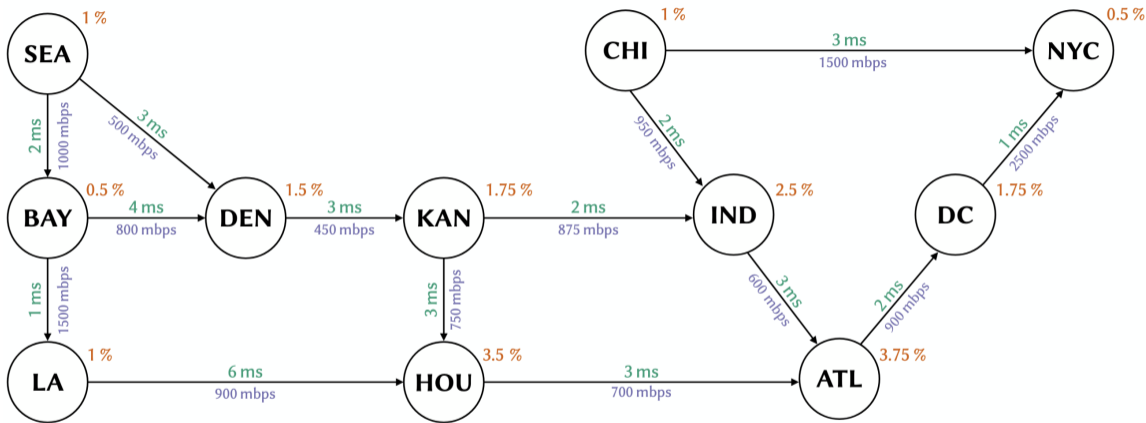

Recap: Network Modeling and Verification with Weighted NetKAT

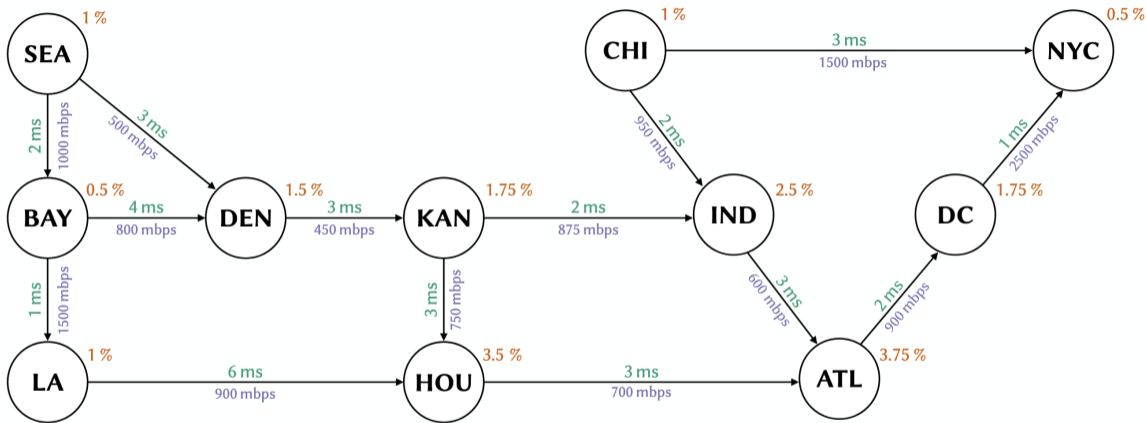

Is all eastbound traffic delivered within 20ms?

Recap: Network Modeling and Verification with Weighted NetKAT

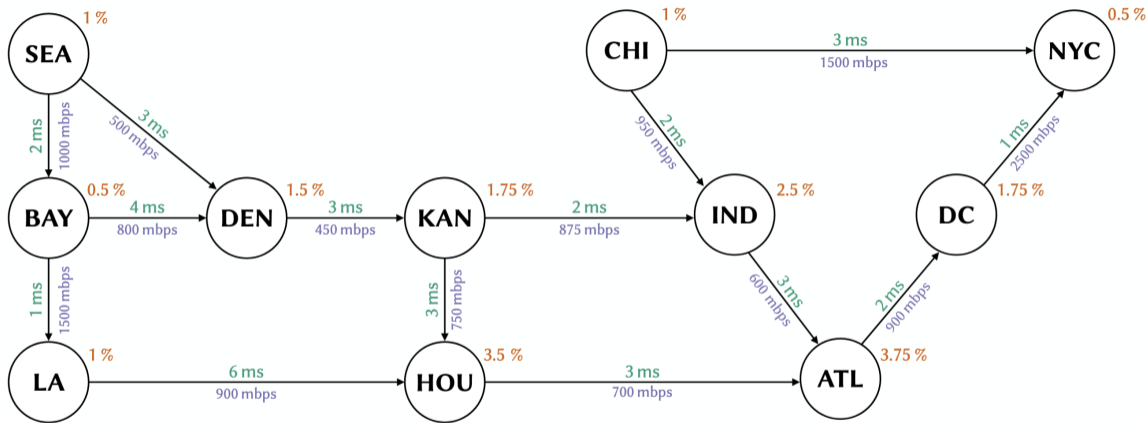

Is all eastbound traffic delivered within 20ms?

Where does the model come from? How to make models concise?

Infer automaton through oracle (membership and equivalence queries)

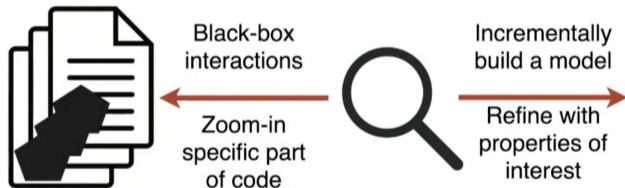

Infer automaton through oracle (membership- and equivalence queries)

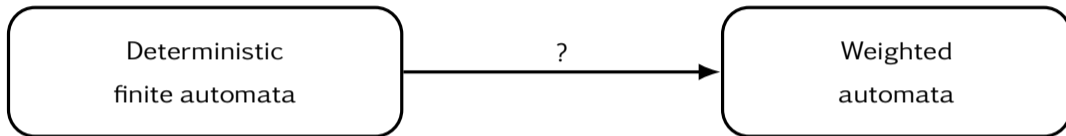

L^* algorithm [Gold, Angluin 80's]

$\underbrace{\mathcal{L} \in 2^{A^*}}_{\text{regular language}}$

$\underbrace{\mathcal{L} \in S^{A^*}}_{\text{weighted language over semiring } S}$

Infer automaton through oracle (membership- and equivalence queries)

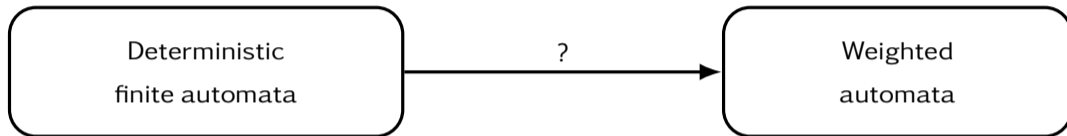

L^* algorithm [Gold, Angluin 80's]

$\underbrace{\mathcal{L} \in 2^{A^*}}_{\text{regular language}}$

$\underbrace{\mathcal{L} \in S^{A^*}}_{\text{weighted language over semiring } S}$

Our approach [submitted to CAV]:

SMT-Based active learning as a practical alternative to L^*

Our Approach: SMT-Based Active Learning of Weighted Automata

Using SMT-solving, we learn **minimal** Weighted Automata for:

1. The Tropical Semiring: $(\mathbb{N} \cup \{\infty\}, \min, +, 0, \infty)$
Application: Learn latencies

Our Approach: SMT-Based Active Learning of Weighted Automata

Using SMT-solving, we learn **minimal** Weighted Automata for:

1. The Tropical Semiring: $(\mathbb{N} \cup \{\infty\}, \min, +, 0, \infty)$

Application: Learn latencies

2. The Bottleneck Semiring: $(\mathbb{N} \cup \{\infty, -\infty\}, \max, \min, -\infty, \infty)$

Application: Learn throughput

Our Approach: SMT-Based Active Learning of Weighted Automata

Using SMT-solving, we learn **minimal** Weighted Automata for:

1. The Tropical Semiring: $(\mathbb{N} \cup \{\infty\}, \min, +, 0, \infty)$

Application: Learn latencies

2. The Bottleneck Semiring: $(\mathbb{N} \cup \{\infty, -\infty\}, \max, \min, -\infty, \infty)$

Application: Learn throughput

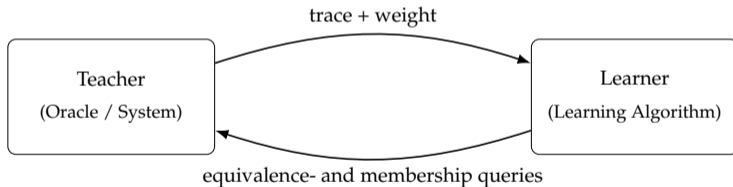

Our Approach: SMT-Based Active Learning of Weighted Automata

Using SMT-solving, we learn **minimal** Weighted Automata for:

1. The Tropical Semiring: $(\mathbb{N} \cup \{\infty\}, \min, +, 0, \infty)$

Application: Learn latencies

2. The Bottleneck Semiring: $(\mathbb{N} \cup \{\infty, -\infty\}, \max, \min, -\infty, \infty)$

Application: Learn throughput

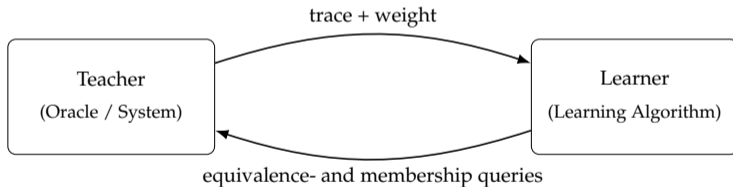

Key idea: Learner uses SMT solving over decidable theories for constructing “increasingly correct” automata

Our Approach: SMT-Based Active Learning of Weighted Automata

Compared to the state-of-the-art, we ...

1. ... need **less interaction with the teacher**

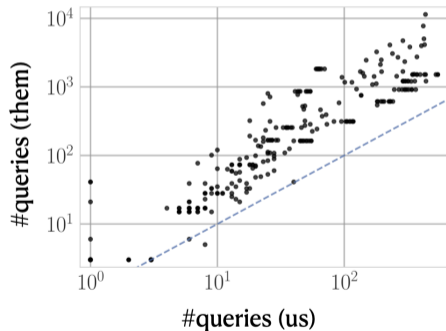

Our Approach: SMT-Based Active Learning of Weighted Automata

Compared to the state-of-the-art, we ...

1. ... need **less interaction with the teacher**
2. ... while producing **significantly smaller automata**

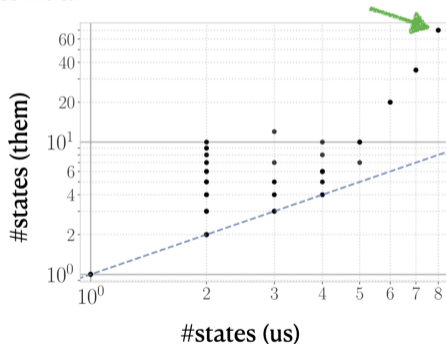
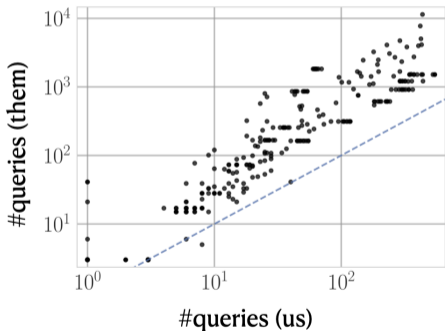

Our Approach: SMT-Based Active Learning of Weighted Automata

Compared to the state-of-the-art, we ...

1. ... need **less interaction with the teacher**
2. ... while producing **significantly smaller automata**

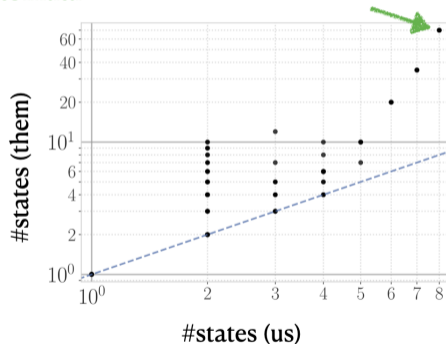
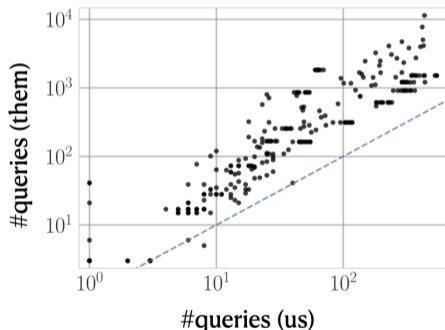

- ▶ Next: **Symbolic data structures** for more efficient learning and verification